

GEF Incorporated
Innovative Solutions in Fiberglass



STRONG RAIL®

ARCHITECTURAL FIBERGLASS HANDRAIL AND FENCING SYSTEMS



GEF Incorporated



STRONGRAIL® Architectural Fiberglass Handrail and Fencing Systems



STRONGRAIL® architectural handrail technology integrates aesthetic appeal with an easy-to-install, cost-effective picket rail system for 1st Class Homes NC in Topsail Island, North Carolina.

STRONGRAIL® architectural handrail and fencing systems are a strong, attractive and safe solution to your structural needs. The standard systems are fabricated from pultruded fiberglass components produced by Strongwell and molded thermoplastic connectors. The railing systems are particularly well-suited to corrosive environments like those found in commercial structures with urban and salt air corrosion. Systems can be made to meet ADA requirements, adding safety and beauty to your property.

STRONGRAIL® architectural fiberglass handrail and fence systems are:

- Corrosion resistant
- Structurally strong
- Impact resistant
- Lightweight
- Easy to field fabricate
- Low in thermal conductivity
- Low electrical conductivity

STRONGRAIL® systems are the result of more than 40 years of experience in the manufacture, design and fabrication of fiberglass handrail and fence systems. The systems offer the following advantages:

- **Ease of Assembly** — STRONGRAIL® systems are produced in lightweight standard sections that include both post and rail. Systems can be prefabricated in large sections and shipped to the site or they can also be fabricated and installed on site with simple carpenter tools.
- **Cost Effective** — An easy-to-assemble design provides reduced labor and maintenance, resulting in long-term savings and elimination of the cost and inconvenience of “downtime for repairs.”
- **Internal Connection System** — All connections fit flush, resulting in a pleasing, streamlined appearance. The internal connections allow the construction of continuous handrail systems.
- **Safety Features** — STRONGRAIL® systems feature low electrical conductivity and exhibit high strength. Systems meet IBC 2006 with a 2:1 factor of safety with a 4-foot (1200mm) maximum post spacing.
- **Low Maintenance** — Corrosion resistant fiberglass with molded-in color will outlast aluminum or steel systems with virtually no maintenance.



The Moody Gardens Convention Center parking garage in Galveston, Texas is also outfitted with STRONGRAIL®. The durable fiberglass architectural handrail system is the ideal solution for a building that experiences high levels of traffic like this one.

An industrial grade polyurethane UV coating is standard on all STRONGRAIL® architectural fiberglass handrail and fencing systems. Also, a polyester resin system is standard for Strongwell's architectural handrail systems but other resin systems are available upon request.



Materials of Construction

STRONGRAIL® is an engineered composite consisting of:

- Continuous glass fibers
- Two continuous strand glass mats
- A synthetic surfacing veil
- Fire-retardant polyester resin

This unique combination provides the ultimate in strength, stiffness and long-term corrosion and UV protection.

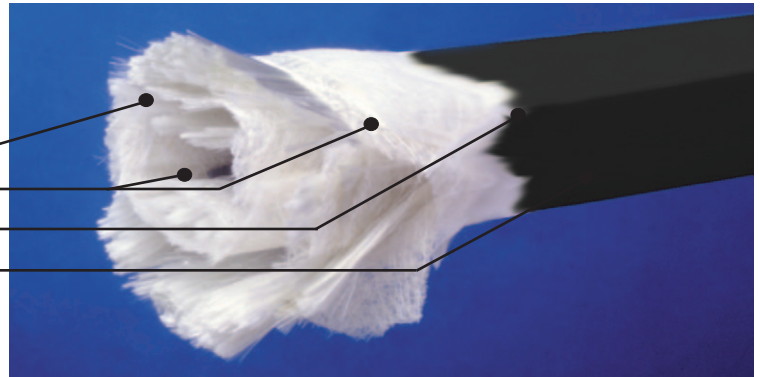

Standard STRONGRAIL® Options

When choosing the best STRONGRAIL® fiberglass architectural handrail system for your project, several options are available to achieve the look you need.

- **Top Railing:** 2" square top rails or 3" rounded top rails
- **Pickets:** square or round
- **Colors:** white or black color (other custom colors are available upon request)



Rounded STRONGRAIL® system with square pickets in white.



White, square STRONGRAIL® system with round pickets.



Square, black STRONGRAIL® system with square pickets.

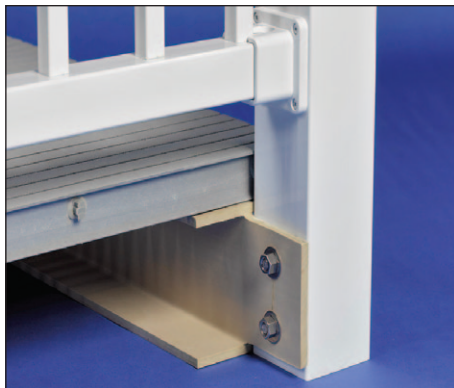

STRONGRAIL® architectural handrail and fencing systems mount quickly and easily to posts and walls.



A white, square STRONGRAIL® architectural handrail system with round pickets.

STRONGRAIL® Handrail Applications



STRONGRAIL® with square pickets and a rounded top rail was produced in a custom color to compliment the exterior of this residential area.



This sun deck wrapped with STRONGRAIL® will outlast wood, PVC, aluminum and steel systems with virtually no maintenance.



Typical 2" Square Top Rail Construction

Picket Specifications

Pickets are available as 1" round or 1" square tubes spaced at 4.75" on center.

Connection Details

All components secured with an epoxy adhesive.

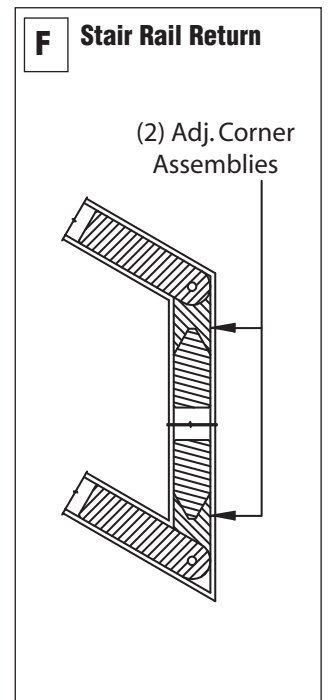
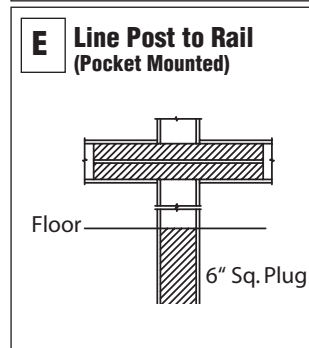
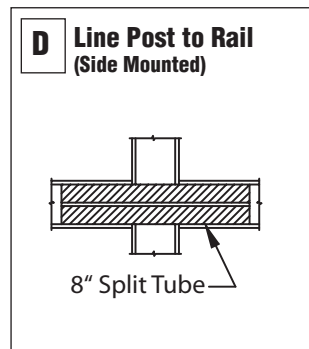
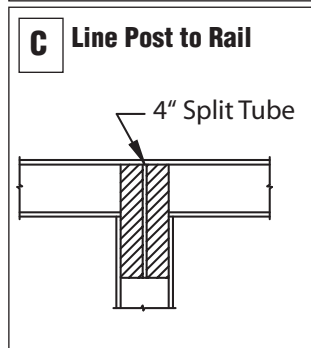
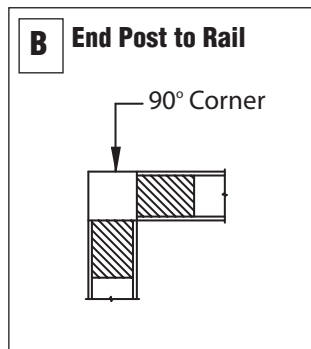
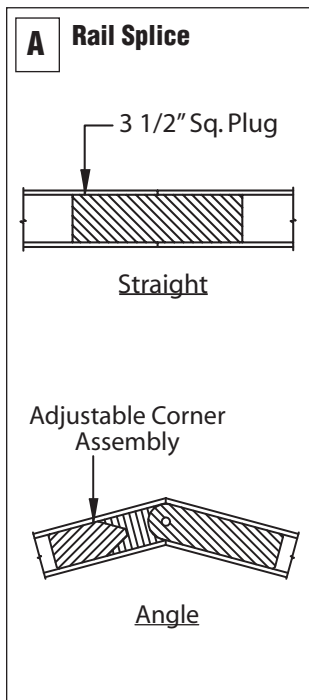
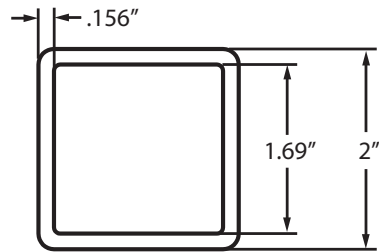
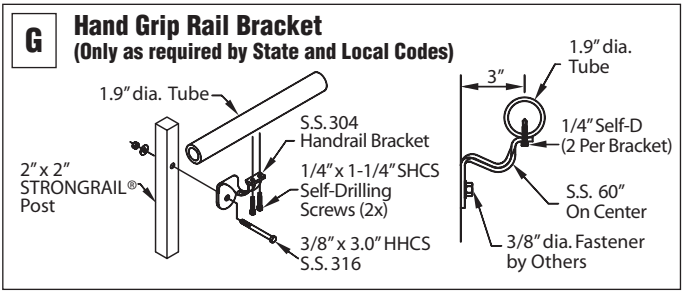
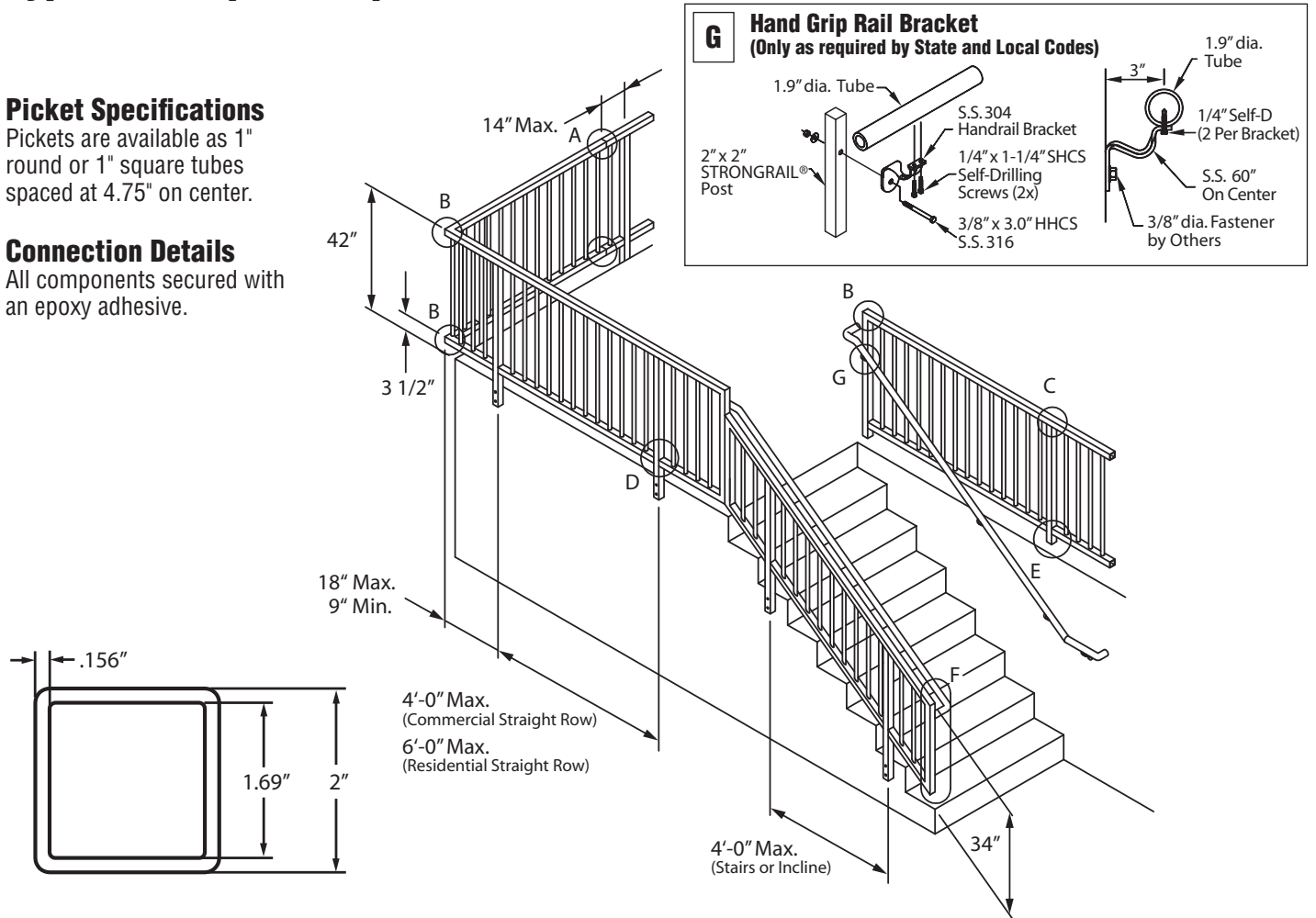



Typical 3" Rounded Top Rail Construction

Picket Specifications

Pickets are available as 1" round or 1" square tubes spaced at 4.75" on center.

Connection Details

All components secured with an epoxy adhesive.

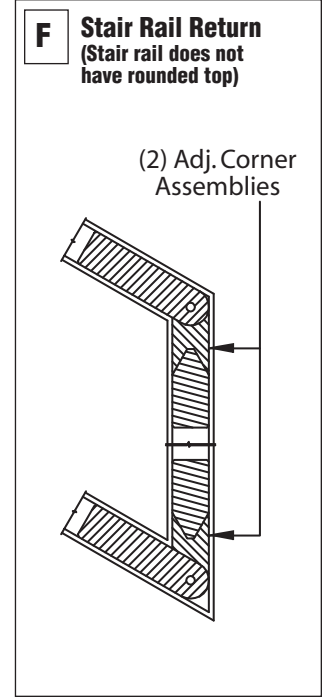
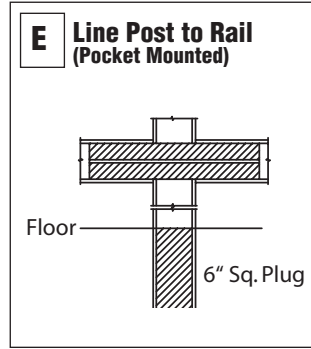
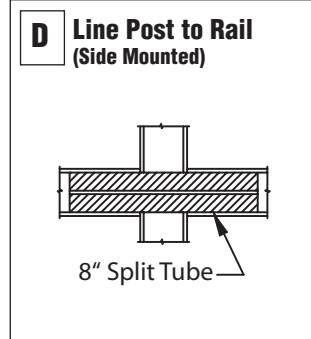
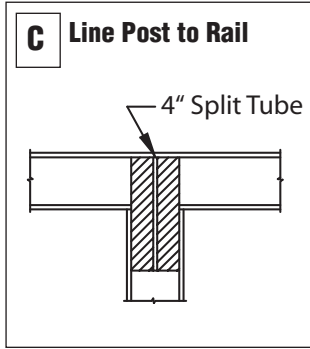
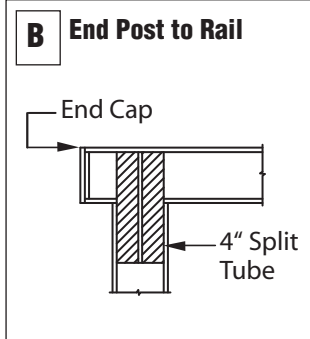
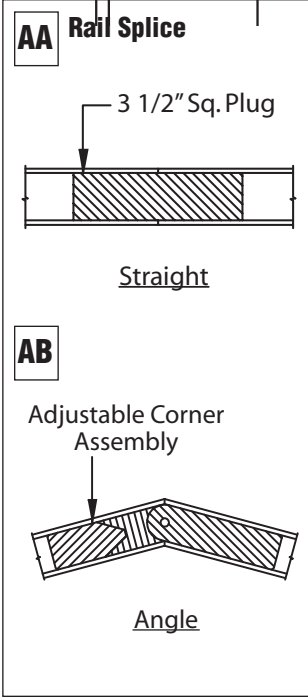
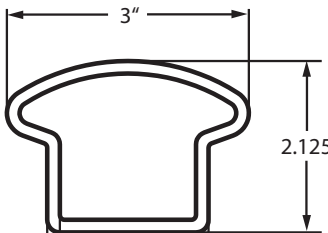
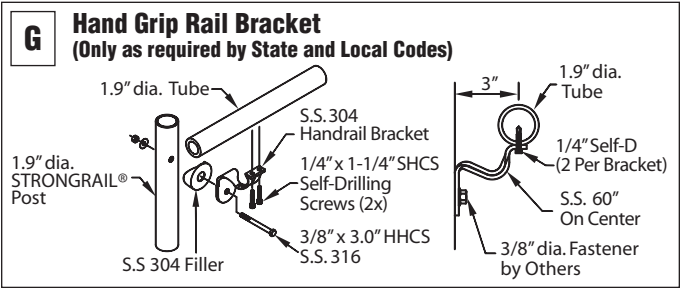
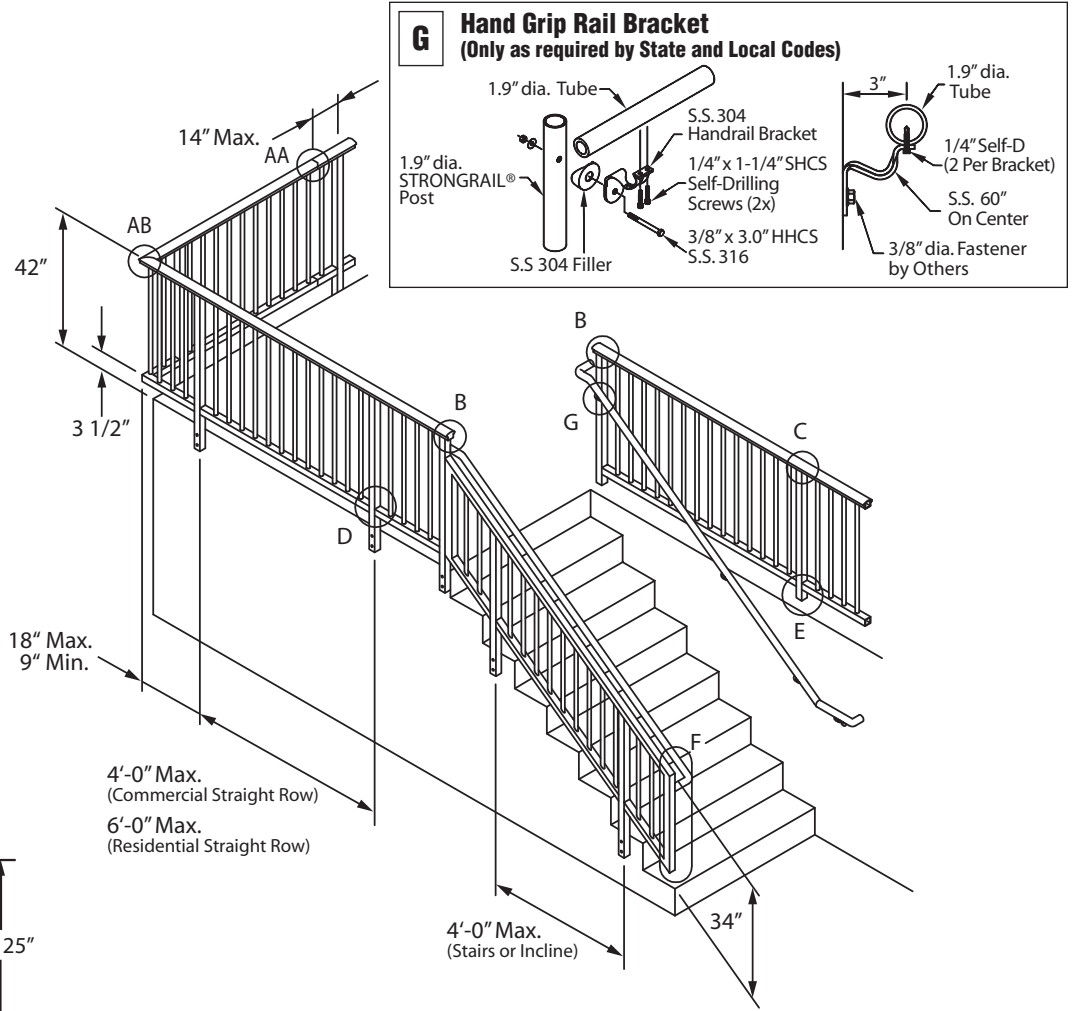



Typical 2" Square Wall or Post Construction

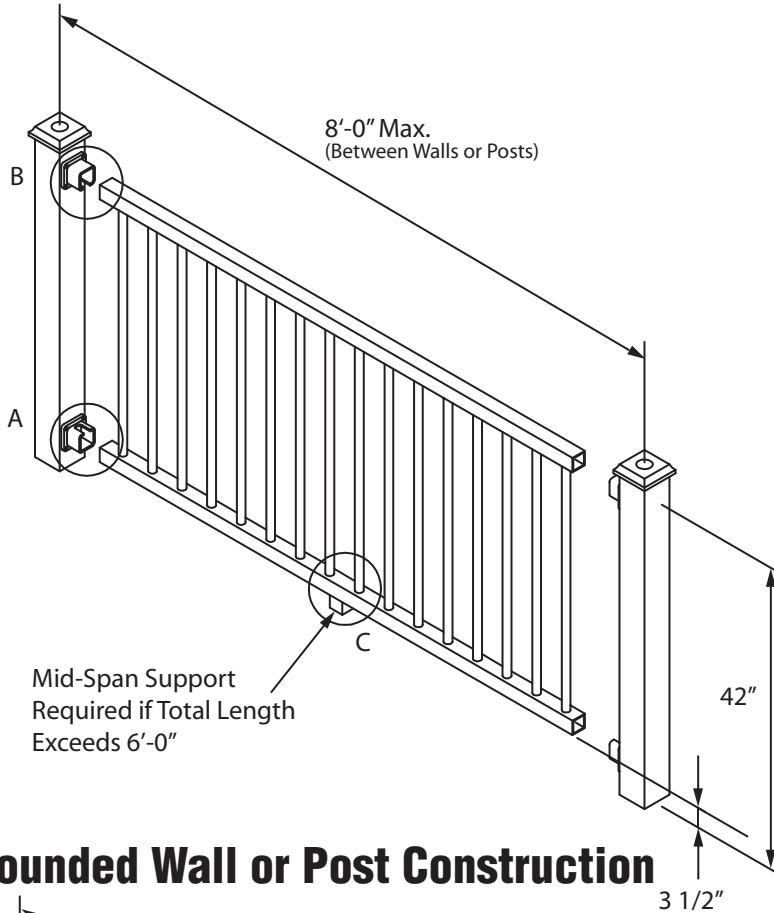

Connection Details

All components secured with an epoxy adhesive.

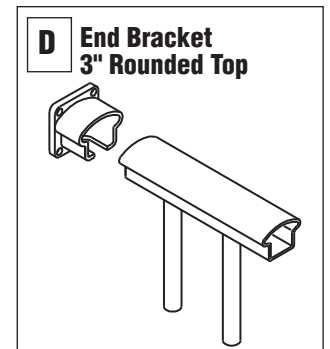
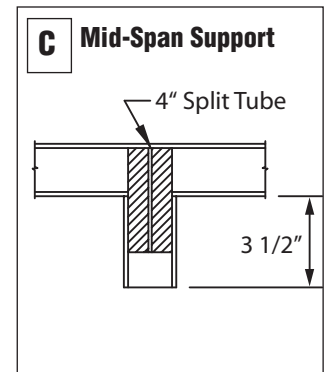
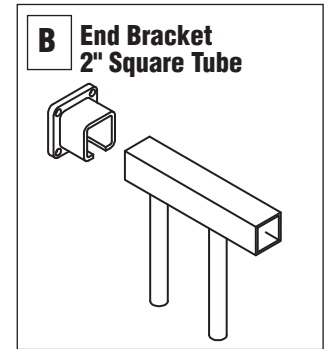
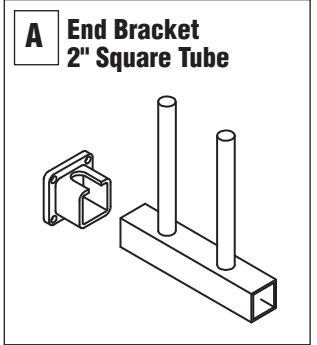

Typical 3" Rounded Wall or Post Construction

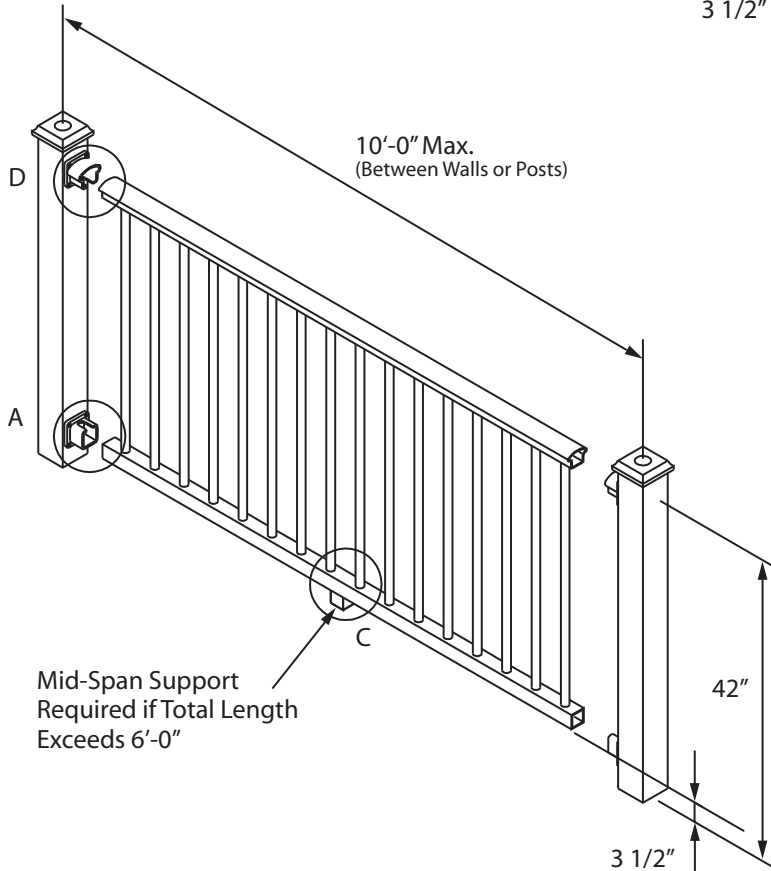



STRONGRAIL® Architectural Fencing Systems

Design Criteria

- **Maximum bending moment on post:** 8400 in-lb (Lateral load, P = 200 lb is applied at height of 42 inches above base)
- **Wind load:** 30 psf (Applied as a concentrated load to the top of post)
- **Square Rail and Post dimensions:** 2" x 2" x 0.156" or 4" x 4" x 0.156"
- **Picket diameter:** 1.0 inch
- **Picket spacing:** 4.75 inches on center

| STRONGRAIL® 2" x 2" Post Spacing | | | |
|----------------------------------|--------------|------------------|------------------|
| FENCE HEIGHT | MAXIMUM SPAN | RECOMMENDED SPAN | PICKETS PER SPAN |
| 48" (4.0') | 115" | 96" (8.0') | 19 |
| 60" (5.0') | 77" | 72" (6.0') | 14 |
| 72" (6.0') | 53" | 48" (4.0') | 9 |

NOTE: For fence height above 72" (6.0') contact Strongwell.

Alternate Post Base Plate Detail

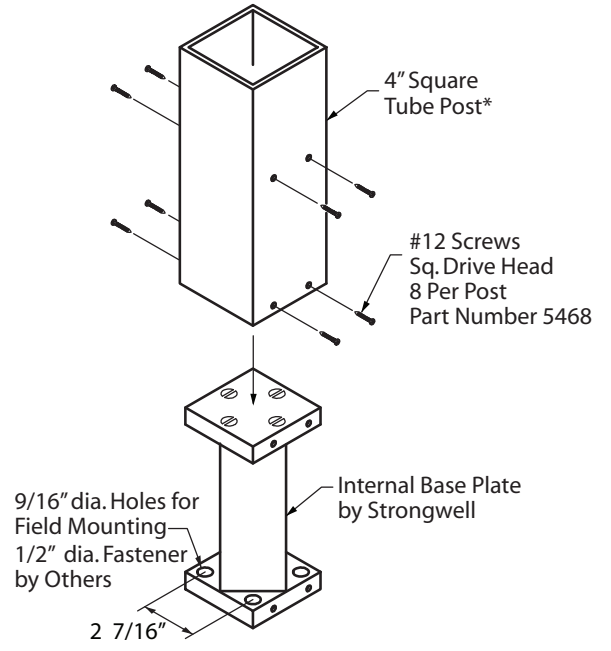

* 4" x 4" square tube post may be spaced 10' on center.

STRONGRAIL® Fencing Applications



Crusader Fence Co, Inc. selected STRONGRAIL® fiberglass architectural fencing system for customer San Mateo County Transit District in California. The handrail serves as a safety fence, preventing pedestrians from contacting electrified train track rails.



STRONGRAIL® outlines the entrance to the New Mexico Military Institute. The fiberglass fencing's low maintenance, ease of installation and aesthetic quality were driving factors behind the institute's selection of STRONGRAIL®.



Custom Handrail and Fencing Applications



This custom half round top rail is used by Fairfield Inn hotels to reduce maintenance and provide long lasting good looks.



A custom handrail system installed for Karlo's Bistro blends with surrounding architecture and adds aesthetic appeal.

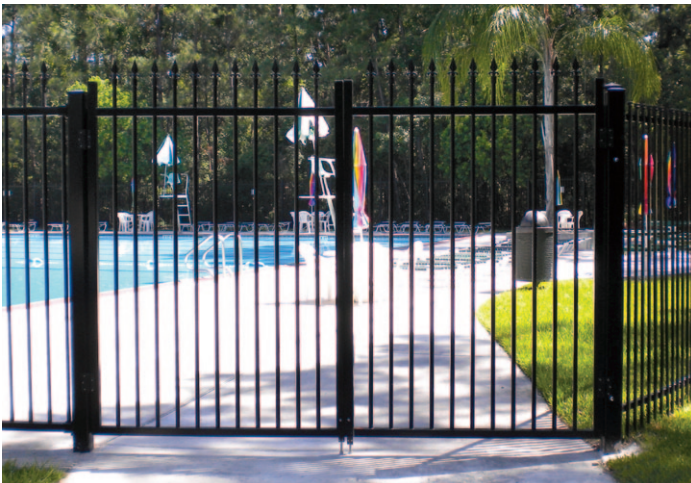

An 8' tall, custom fiberglass fence replaced wrought iron at this Kingwood, Texas community pool. The fiberglass fence provides aesthetic appeal like the wrought iron, but without the corrosion problems faced at a pool side environment.



The Moody Gardens Theme Park has embraced the low maintenance and corrosion resistance of Strongwell's custom fiberglass handrail systems. A day dock at the popular destination features an ADA compliant custom handrail system that uses several of Strongwell's pultruded fiberglass structural profiles.



GEF INCORPORATED

6497 WINFIELD ROAD • WINFIELD, WEST VIRGINIA 25213
304/755-1600 • 304/755-3150 FAX • 800/784-0529 TOLL FREE
www.gefinc.com